



Spray with **Passion**  
Demand **Quality**  
Deliver with **Pride**



# GRAPHENE CERAMIC COATING 1140 PRO KIT



Ready-to-Use

Formulated to incorporate graphene oxide, **AMERICAN ICON GRAPHENE CERAMIC COATING 1140 PRO KIT** creates a more durable glass-like coating on the vehicle surface to additional protection and improved appearance. This advanced formula is suitable for all surfaces including paint, glass, chrome, plastic/trim, headlights, wheels, calipers, wraps, and more. With twice the activity of standard ceramic formulations American Icon Graphene Ceramic 1140 Pro Kit can be used for gelcoat in Marine and RV applications, as well as on automotive clear coats.

**Jumbo Bottle: One bottle coats two cars!**

#### Recommended uses:

Automotive refinish graphene ceramic coating

#### Kit Contains:

100mL Graphene Ceramic Coating 1140 Pro, Two High-density Microfiber Cloths, One Block Applicator

#### FEATURES:

- >10H Hardness, 9+ Years of Protection
- Less prone to water spotting
- High stain resistance against bugs, saps, droppings, etc.
- High scratch resistance during the washing process
- Easier to apply than other Ceramic Coatings
- Increases UV surface protection
- Increased depth and clarity to all surfaces
- Lower sliding angle with water evacuating at angles less than 10-15°
- Higher contact angles averaging 114°
- UV Tracing Technology™

#### CERAMIC COATINGS

PRODUCT	SIZE	CODE
Graphene Ceramic Coating 1140 Pro Kit	100mL	11403

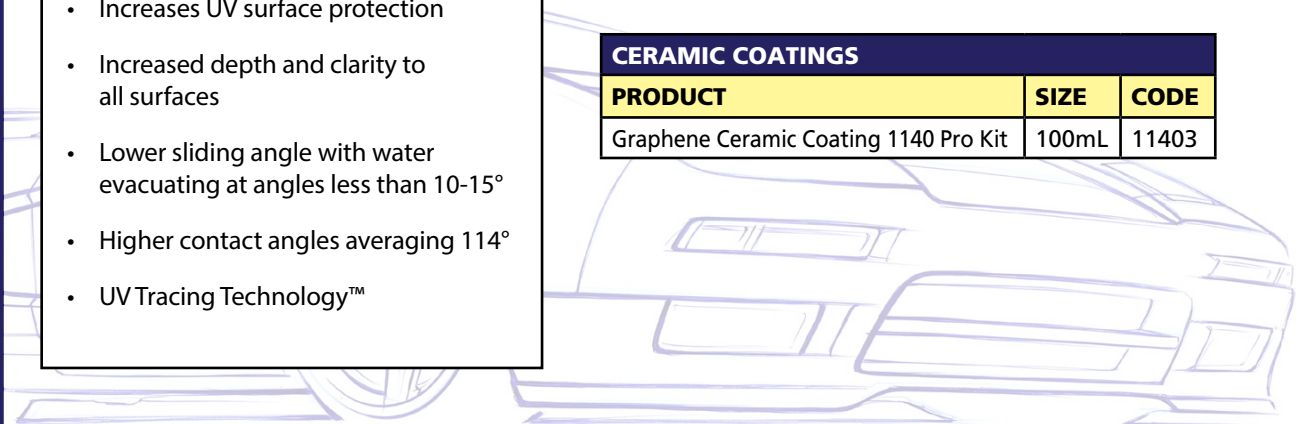



Spray with **Passion**  
Demand **Quality**  
Deliver with **Pride**

## GRAPHENE CERAMIC COATING 1140 PRO KIT

### PRODUCT DESCRIPTION

Formulated to incorporate graphene oxide, American Icon Graphene Ceramic Coating 1140 Pro Kit creates a more durable glass-like coating on the vehicle surface for additional protection and improved appearance.

This advanced formula is suitable for all surfaces including paint, glass, chrome, plastic/trim, headlights, wheels, calipers, bed liners, and wraps.

With twice the activity of standard ceramic formulations, American Icon Graphene Ceramic Coating 1140 Pro can be used for gelcoat in Marine and RV applications, as well as on automotive clear coats.

### COLORS: GLOSS CLEAR

**RECOMMENDED USES:** Automotive refinish graphene ceramic coating

**PROPER SURFACE PREPARATION IS ESSENTIAL TO ACHIEVE A HIGH QUALITY FINISH. READ THE SDS SHEET AND WEAR PROPER PROTECTION, WHICH MAY INCLUDE GLOVES, EYE PROTECTION, AND/OR OTHER PROTECTIVE DEVICES.**

### SURFACE PREPARATION / DIRECTIONS

Thoroughly clean to remove old waxes, sealers, tar, iron, and other contaminants. Embedded contaminants should be removed with a clay bar/glove and non-waxed lubricant. Remove scratches with a non-waxed/non-sealant compound and polish to remove defects. Wipe all surfaces with American Icon R-S200 Surface Prep cleaner or an IPA prep solution for ceramic coatings.

Shake well before and during use. Saturate a suede applicator or similar with numerous drops of material from the dripper bottle. Apply the coating to a 3x3 ft<sup>2</sup> area of the vehicle using a cross-hatch pattern with slight overlap to level the product. Allow the coating to cure for 1-2 minutes and gently remove excess product using a clean suede cloth or low nap microfiber towel. You can check for missed areas with a UV light. Do NOT allow coating to come in contact with water for 24-48 hours while curing - if it does, remove water promptly. Apply additional coats with at least one hour between applications or immediately following a single pass around the vehicle. Do NOT apply in direct sunlight or to a hot surface. Cure time is dependent on environmental conditions. Test product on a small inconspicuous area first to gauge cure time. Don't wash vehicle for 7 days after application.

Physical State: Liquid Clear, Black

Odor: Solvent

Flash Point: 39 °C at 995 mbar

Longevity: Up to 9 Years

Hardness: >10H (ASTM D-3363)

Contact Angle: 105-115° (Clear Coat)

Sliding Angle: 5-15° (Clear Coat)

Thickness: 3-4 micron

Adhesion: 5B - No Coating Loss (ASTM D-3359)

Mandel Bend: No Coating Loss @ 180° (ASTM D-522)

Impact: 80/80 inch-lbs (ASTM D-2794)

Temperature Resistance: 700-1000°C / 1200-1800°F

### SAFETY INFORMATION

**DANGER!** FLAMMABLE LIQUID AND VAPOR. MAY BE FATAL IF SWALLOWED AND ENTERS AIRWAYS. CAUSES SKIN IRRITATION. MAY CAUSE AN ALLERGIC SKIN REACTION. SUSPECTED OF CAUSING CANCER.

#### Contains Stoddard Solvent,

**1,2,4-trimethylbenzene:** MAY AFFECT THE BRAIN OR NERVOUS SYSTEM CAUSING DIZZINESS, HEADACHE, OR NAUSEA. MAY CAUSE EYE, SKIN, NOSE, AND THROAT IRRITATION. NOTICE: Repeated and prolonged exposure to solvents may lead to permanent brain damage. Eye watering, headaches, nausea, dizziness and loss of coordination are signs that solvent levels are too high. Intentional misuse by deliberately concentrating and inhaling the contents may be harmful or fatal. To avoid breathing vapors or spray mist, open window and doors or use other means to ensure fresh air entry during application and drying.

**Keep away from heat and flame. Use only with adequate ventilation.** Do not breathe vapors, spray mist or spraying dust. Do not get in eyes or on skin. WEAR A PROPERLY FITTED VAPOR/PARTICULATE RESPIRATOR APPROVED BY NIOSH FOR USE WITH PAINTS, eye protection, gloves, and protective clothing during application (or sanding) and until all vapors and spray mist are exhausted. In confined places or in situations where continuous spray operations are typical, or if proper respirator fit is not possible, wear a positive-pressure, supplied air respirator approved by NIOSH. In all cases, follow respirator manufacturer's directions. Do not permit anyone without protection in the painting area. Close container after each use. Store in a well-ventilated place. Keep cool.

**FIRST AID:** Do not leave affected person unattended. Remove victim out of the danger area. Keep affected person warm, still and covered. Take off immediately all contaminated clothing. In all cases of doubt, or when symptoms persist, seek medical advice. In case of unconsciousness place person in the recovery position. Never give anything by mouth.

**In Case Of Inhalation:** If breathing is irregular or stopped, immediately seek medical assistance and start first aid actions. In case of respiratory tract irritation, consult a physician. Provide fresh air.

**In Case Of Skin Contact:** Wash with plenty of soap and water.

**In Case Of Eye Contact:** Remove contact lenses, if present and easy to do. Continue rinsing. Irrigate copiously with clean, fresh water for at least 10 minutes, holding the eyelids apart.

**In Case Of Ingestion:** Rinse mouth with water (only if the person is conscious). Do NOT induce vomiting. Immediately call a poison center/doctor.

**IN CASE OF FIRE:** Use sand, carbon dioxide or powder extinguisher to extinguish.

**SPILL:** Absorb with inert material and dispose of in accordance with applicable regulations. Keep away from drains, surface and ground water.

**DISPOSAL:** Empty container with product residue may still be flammable; follow all hazard statements until it has been disposed of. Contains organic solvents which may cause adverse effects on the environment if disposed of improperly. Consult your sanitation department for more information on disposal of empty containers. Disposal of wastes containing either organic solvents or free-liquids in landfills is prohibited. **Local requirements vary; contact your state-designated environmental agency for information concerning re-use, recycling, or disposal of solvent-borne paint.**

**FOR PROFESSIONAL USE ONLY NOT FOR RESIDENTIAL USE**

**KEEP OUT OF REACH OF CHILDREN**

**Refer to Material Safety Data Sheet available from your dealer for further safety and handling information.**

**VOC : 1.249%**

**⚠ WARNING: CANCER - WWW.P65WARNINGS.CA.GOV**

